

Installation Guide

SBTL9000 Series

Version: 1.0

1 Installation Requirements

1. It is recommended that the swing barrier must be installed on a horizontal solid platform with a height of 50mm to 100mm.
2. It is also recommended that the swing barrier turnstile should not be used in the corrosive environment.
3. Make sure the ground wire of the system is reliably connected to avoid personal injuries or other accidents.
4. After installation, check if the connection is done correctly at the connecting points of the ground wire, at the connector assemblies and wiring points of the circuits, as well as at each movable part of the swing barrier turnstile. Any loose nuts, screws and other fasteners should be tightened in time to avoid any failures caused by long-time operations.

2 Installation Position

The installation position of the swing barrier turnstile depends on its size. A distance of 100mm between the swing barrier turnstile and the wall needs to be reserved for ease of opening the top cover of the machine to perform maintenance and adjustment. The reference figure is shown below:

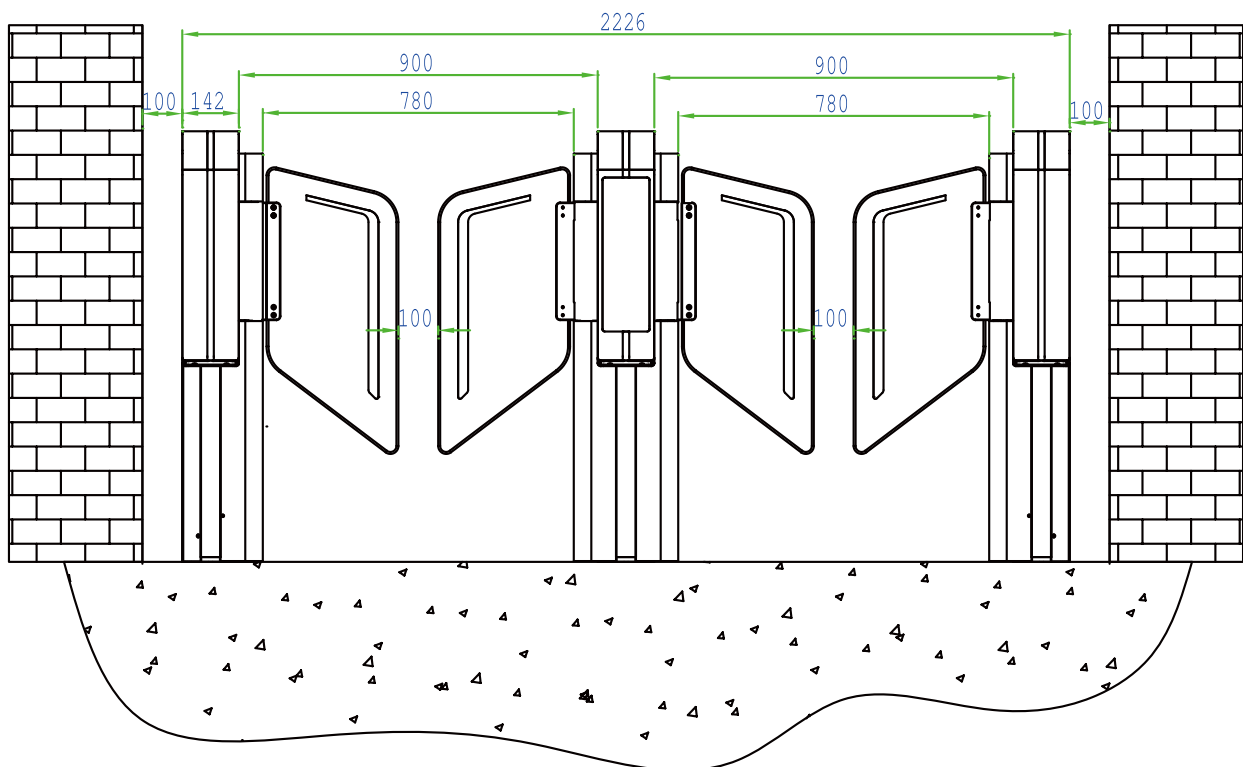

Figure 2-1 SBTL9000 Series Dual-lane

3 Preparation

1. **Tools:** A measuring tape, an adjustable wrench, an impact drill and a small screwdriver (included in the package).
2. **Material:** A PVC anti-€re and insulation tube (diameter] 25mm), standard three-core power extension wire, tether cable (random con€guration), M12 expansion screws (included in the package).
3. Thread the connection wire of the device through the tube before assembly.
4. The power and signal wires should be set separately to easily distinguish strong and weak power. Please invite professional personnel to complete the wiring. The device must be connected to the ground.

Below is the outline and dimensions of SBTL9000:

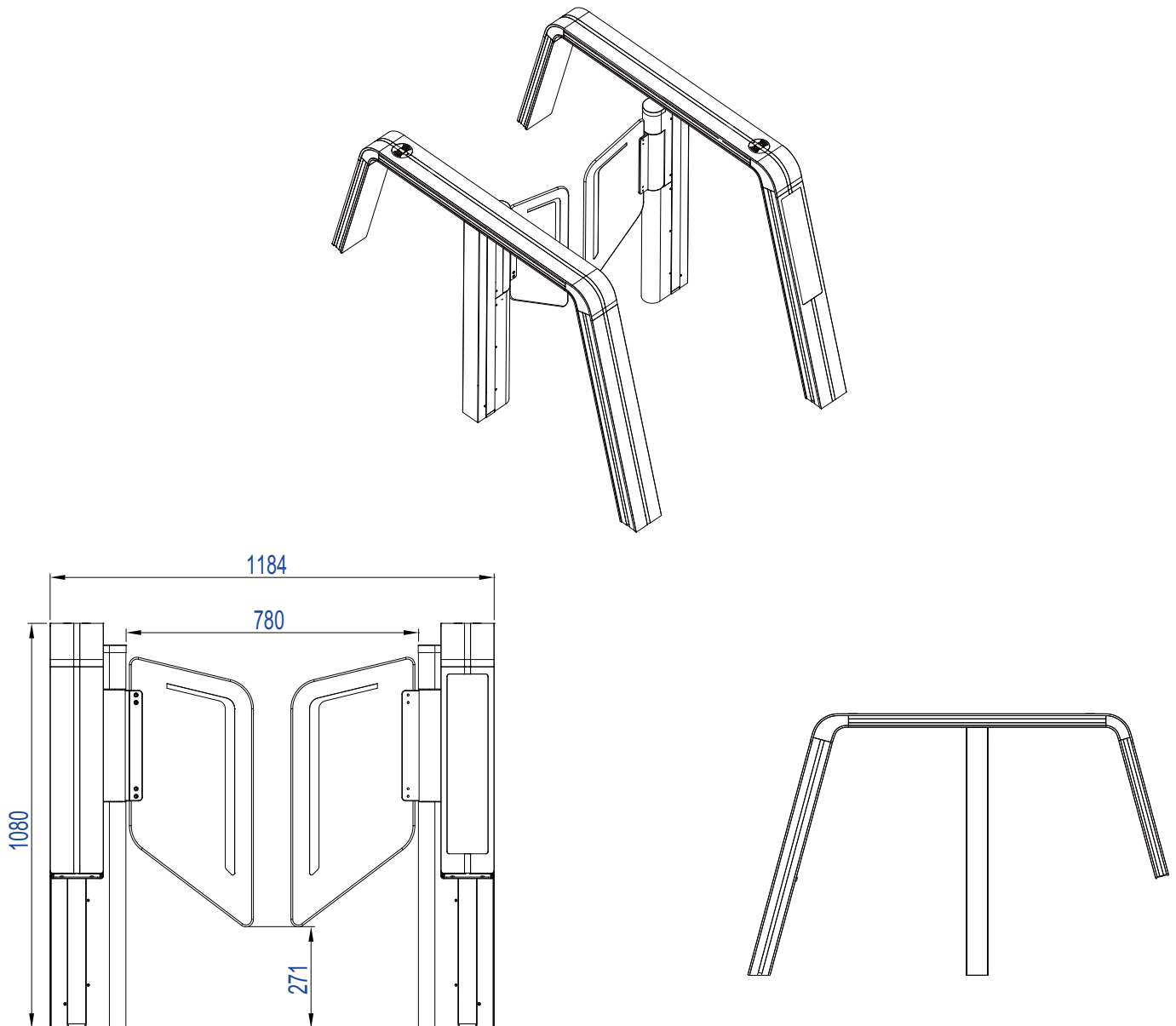

Figure 3-1

4 Installation

1. Prepare the tools for product installation and sort out the auxiliaries according to the packing list.
2. Mark the screw hole at the centre of the stand, and the edge of the chassis base on the ground according to the sizes as shown on the Figure 4-1.
3. Drill the holes with J 14 and embed M12 anchor screws or expansion screws. As shown on the Figure 4-2.

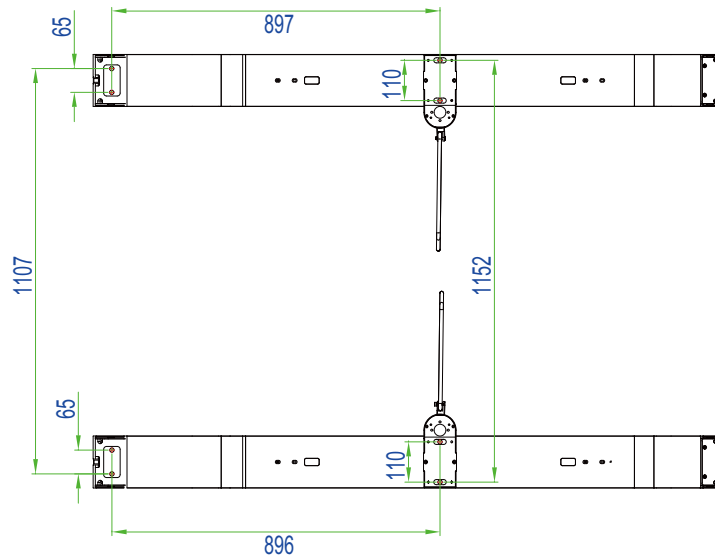
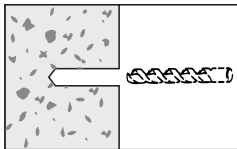
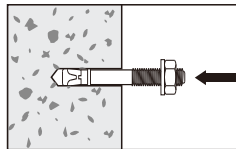

Figure 4-1



1. Drill hole



2. Implantation of the screw

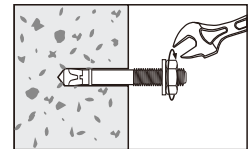

3. Fix screw

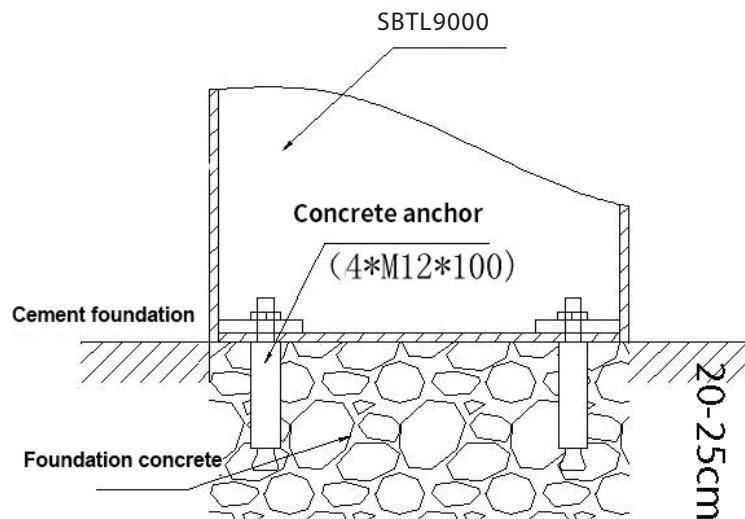

Figure 4-2

4. Place the swing barrier turnstile according to the sizes and positions as shown in the figure before installation and fixing.
5. For the outlets of the concealed cables, please refer the below diagram indicating the mounting holes. The input voltage for this swing barrier turnstile is AC100V-120V/200V-240V and its master and slave are connected by an 8-core cable (signal) and a 2-core cable (power). When installing the swing barrier turnstile, the user only needs to connect it to the corresponding ports. Note that the PVC conduits are laid 100mm under the ground, with the height of the exposed part not exceeding 100mm. In addition, the conduit outlet is bent back to prevent the ingress of water into the conduit.

SBTL9000 series installation holes and cabling positions is shown in Figure 4-3:

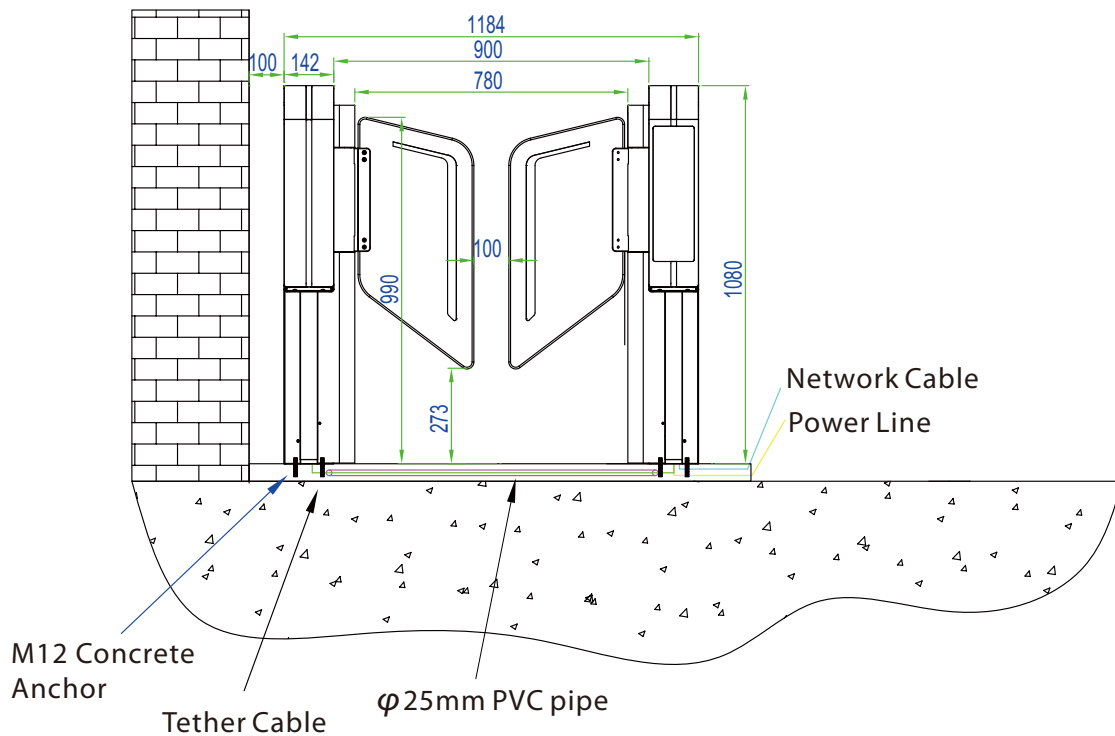
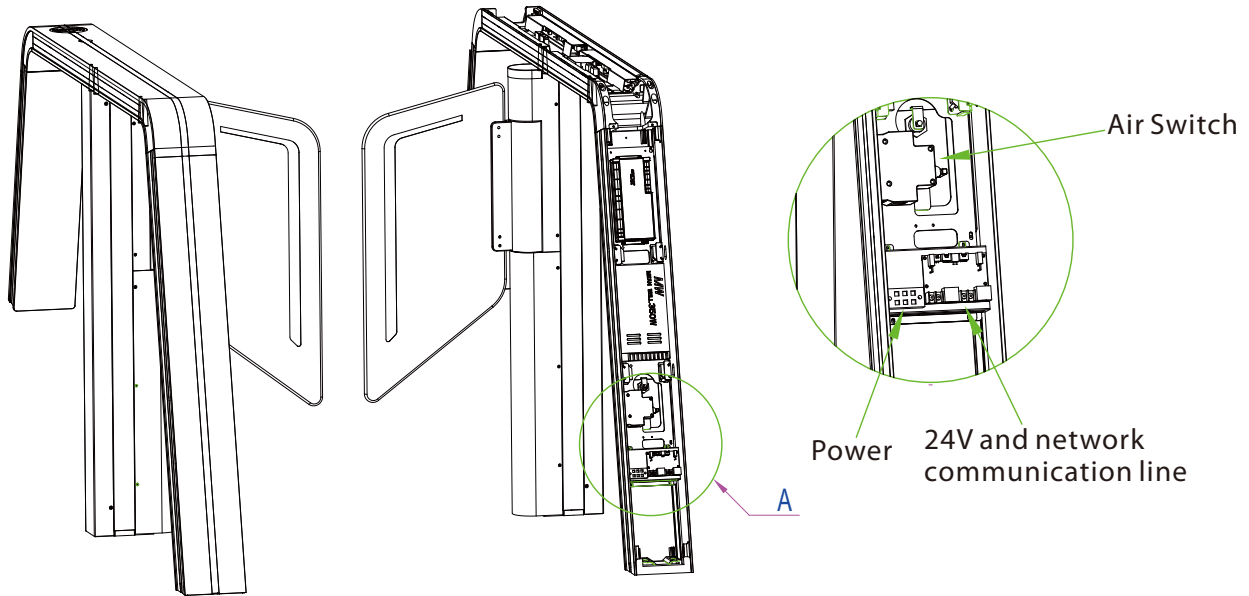

Figure 4-3

6. Connect the online cables and perform the power-on test. Wait for 10 seconds for the turnstile to complete the self-test program. At the same time, check if the indicators work properly. If everything works fine, you can tighten the screws and fix the device. If an exception occurs, please contact your vendor.
7. It is recommended that a warning line be marked on the ground after installing the device, so as to prompt the pedestrian to stand behind the warning line when swiping the card. As shown in Figure 4-4:

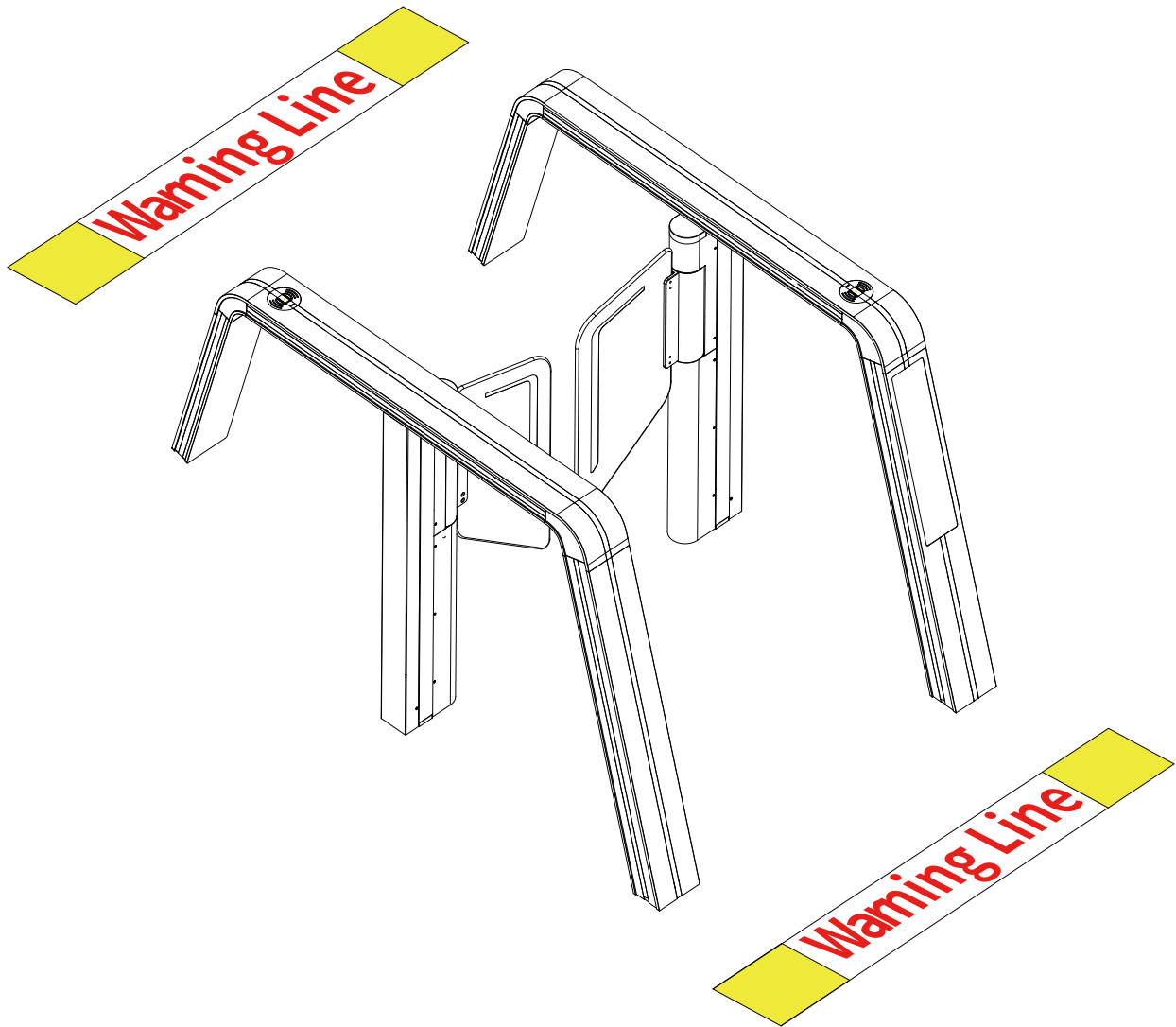
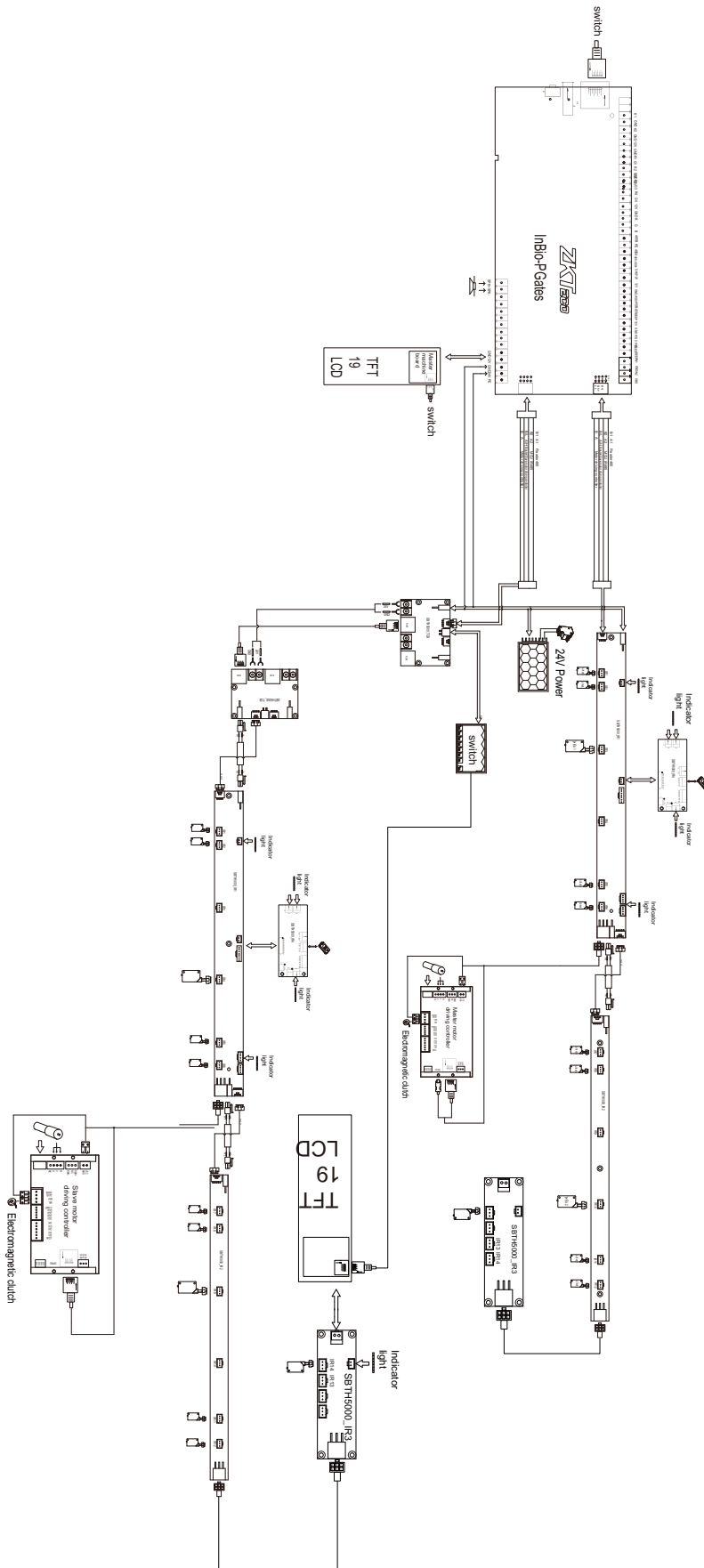

Figure 4-4

5 Wiring Diagram

Below is the wiring diagram:



ZKTeco Industrial Park, No. 32, Industrial Road,

Tangxia Town, Dongguan, China.

Phone : +86 769 - 82109991

Fax : +86 755 - 89602394

www.zkteco.com

